

DAKAR PLUS 450

CONSTRUCTION MATERIAL CUTTING MACHINE

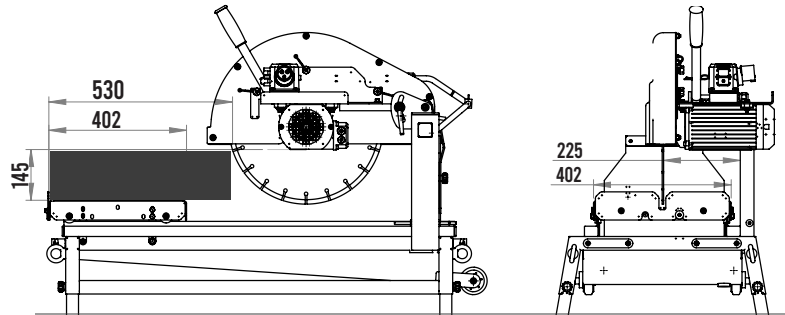

Po. Juncaril, C/Albuñol, Parc. 250
18220 Albolote, Granada, Spain
Telf. +34 958 490 410
Fax: 34 958 466 645



CONSTRUCTIVE DESIGN

This machine is designed to cut various materials such as concrete blocks, clay blocks, marble, granite, and more.

Its welded tubular frame provides an ideal balance of strength and reduced weight, while the removable leg system makes the machine compact and easy to transport and store.

Thanks to its single-phase IE3 high-efficiency motor, it can be easily connected to a standard electrical supply.

QUICK CONNECTOR

EMER. STOP



MOTOR IE3 HIGH EFFICIENCY

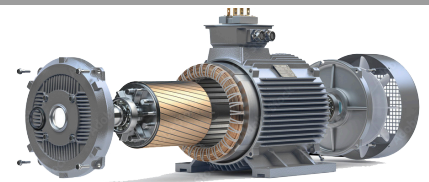

TECHNICALS SPECS

Motor: M 230 v 2,2 Kw (3HP) 50Hz
Pump 230 v / 50 w
Blade Ø Ext. max 450 mm
Shaft Ø 25,4 mm
Length max corte 530 mm
High max 1 pasada 145 mm
High max 2 pasadas 180 mm
Weigh 57 Kg
Dimension L x A x H 1322 X 804 X 1427 mm
Package L x A x H 1480X830X1190 mm

5

Blade not included
R-6721450 Combi Blade
R-6701450 Reinforced Concrete Blade

CUTTING HEIGHT

The cutting head with height locking allows step-by-step cutting of extremely hard materials such as natural stone, granite, marble, and others.

The integrated spring system ensures controlled downward cutting movement and a quick return to its initial position.

The blade guard is designed to use diamond blades of Ø350, Ø400, and Ø450, achieving a maximum cutting height of 148 mm in a single pass.

