



# S<sup>★</sup>ima

 ORIGINAL USER GUIDE



## SPIRAL-26

C/ Albuñol, par.250  
Pol. Ind. Juncaril,  
18220 ALBOLOTE (Granada) ESPAÑA  
Telf: (+34)958 490 410  
Fax: (+34) 958 466 645  
info@simasa.com  
www.simasa.com



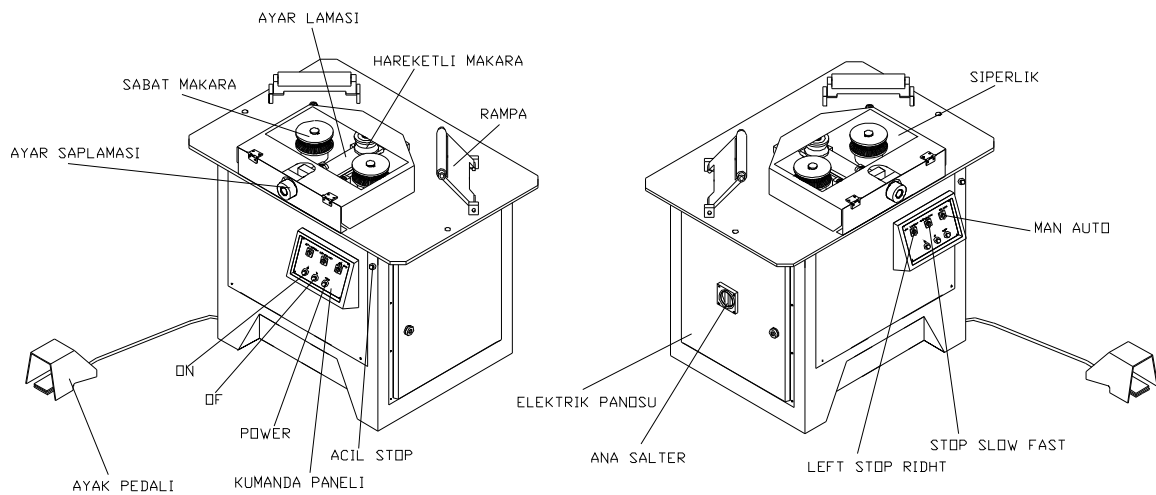

## Overview

The **SPIRAL-26** Spiral Bending Machine is designed and manufactured only for spiral bending of round and rigid metallic bar materials. All other purposes of use are not allowed. This machine can be operated with different optional apparatus for various shapes of bending. In order to get the best output from your **SPIRAL-26** locate it in such a position so as to be operated easily, and to provide more efficient work from the Operator. Therefore, the site where the machine will be operated is to be near the storage area of construction iron, and to be covered with a shed, which would be more convenient. We recommend you to locate workbenches in both sides of the machine. The length of each bench is to be the longest length of the material to be bent. By means of support of these benches, the Operator will be able to bend any kinds of material without lifting and turning over them, and thus the possibility of more productive work may be obtained from the Operator.

## Important Warning

- Prior to operate the machine read through this Operating & Maintenance Manual, carefully.
- Only the qualified personnel are allowed to operate the machine.
- Disconnect the power prior to make checks, maintenance, lubrication, and/or adjustments.
- Observe all guidelines provided in this Operating & Maintenance Manual.

## 1. SET-UP PROCEDURES

- 1.1 Level the machine on a flat and sound ground **(Figure 1)**.
- 1.2 Made the power connection by a qualified electrician.

### **Note: Power Connection**

- 1.3 Plug on the power supply cord of 5x4 mm<sup>2</sup> to the feeding line of main power.
- 1.4 Grounding is to be made for safety. Do not operate the machine without grounded power.

**Grounding Connection:** Follow the procedure below. Connect one end of the ground cable to a copper wire (minimum 16 mm) so as to ensure electrical conductivity. The other end of the cable is to be connected to a tube having ability of conductivity dipped sufficiently into the ground (into the damp soil, preferably), or to a copper plate buried under the soil as deeper as possible.

### **FIGURE 1**

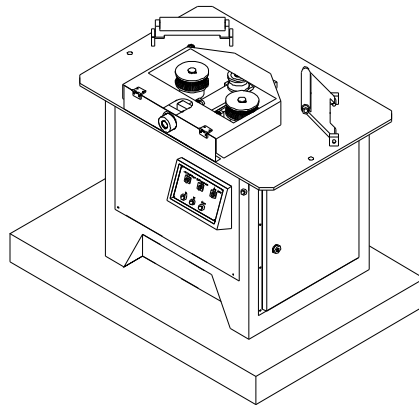

## 1.2. START UP PROCEDURE

- 1.2.1 Check and ensure that the machine is installed in accordance with instructions.
- 1.2.2 Remove all parts (including bending apparatus) from the top surface of the machine.
- 1.2.3 Turn the switch (LEFT/STOP/RIGHT) to the LEFT or RIGHT, and the switch (MAN-AUTO) to the MAN position, and determine the direction of rotation of the machine by pressing the foot pedal down.

**Note:** The clockwise rotation is accepted as the right rotation and the counter clockwise rotation as the left from the front view (the control panel side) of the machine. If the machine rotates counter clockwise in comparison to the turning direction of switch, it means that the phases of power network are reverse. This situation will not create any problem for the operation of machine. In such cases, you may turn the control switch (LEFT/STOP/RIGHT) to the LEFT or RIGHT.

- 1.2.4 Start to make bending adjustments by following determination of rotation.

**FIGURE 2. Control Buttons**

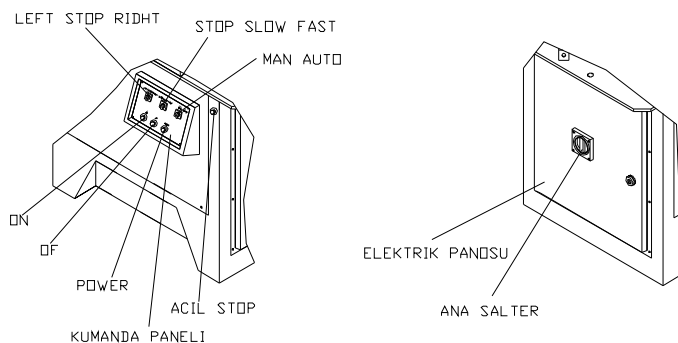

**2 . TECHNICAL SPECIFICATIONS**

**Bending Capacity**

Strength of material	Diameter/ Bendable unit
45 kg/mm <sup>2</sup>	Ø 26x1
65 kg/mm <sup>2</sup>	Ø 22x1
85 kg/mm <sup>2</sup>	Ø 20x1

Model : **SPIRAL-26**  
 Name : **Spiral Bending Machine for Construction Iron**  
 Motor Input Torque : 11,9 – 23,8 Nm  
 Reducer Output Torque : 852,7- 1023,2 Nm

**Dimensions**  
 Width : 0.72 m  
 Length : 1.12 m  
 Height : 0.98  
 Weight : 300 kg

**Motor Specifications**

Power : 1,5-2,5 kW  
 Rate : 697-1387 rpm  
 Voltage : 380 V  
 Frequency : 50 Hz

**3. APPARATUS AND TOOLS SUPPLIED WITH THE MACHINE**

- Foot Pedal : 1 ea

**Proper Fixing Forms of Construction Iron**

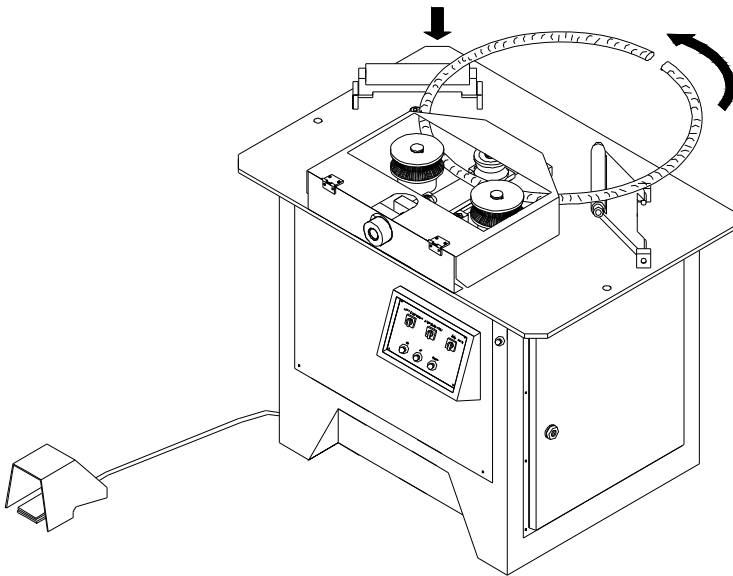

### Improper Fixing Forms of Construction Iron

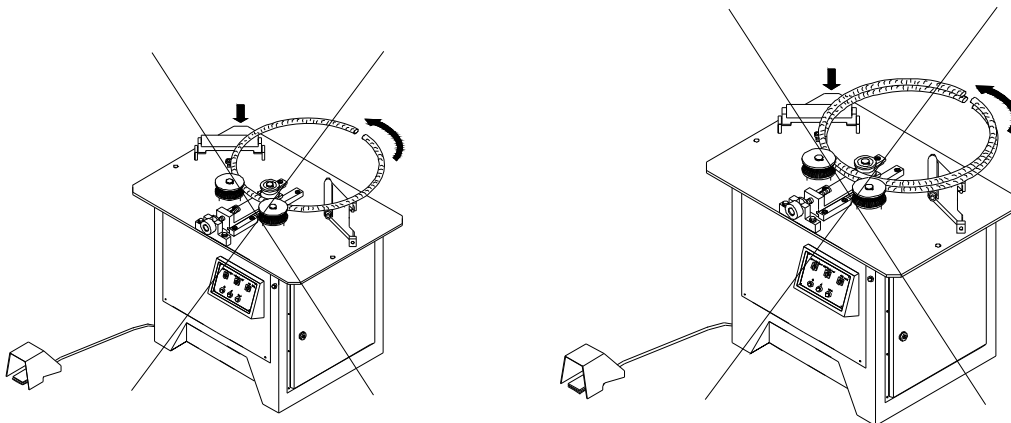

### 4. GUIDELINES FOR SAFETY, AND EFFICIENT USE

- ▼ Do not operate the machine when it is wet.
- ▼ Do not try to make bending using the measurements, dimensions or quantities other than those specified in the name plate.
- ▼ Do not operate the machine when the cover of electric panel is opened.
- ▼ Do not change the electrical adjustments made in ex works.
- ▼ Do not operate the machine without grounded power.
- ▼ Do not operate the machine when protective covers are opened..
- ▼ Do not allow the machine to be operated by those other than the qualified operators.
- ▼ Do not operate the machine without lubrication oil.
- ▼ Do not allow removing the warning labels stuck onto the machine.

- ▼ Do not allow to use the spare parts and apparatus other than the genuine ones manufactured by **SIMA**.
- ▼ Do not try to make bending by using the bent, distorted and cracked apparatus, and/or the sleeves having the inner diameter enlarged.
- ▼ Do not try to make bending material in improper forms. **(Figures 3)**.
- ▼ Do not use pressurised air to clean the machine.
- ▼ In case of need to open the lid of the power panel, ensure that main switch is to be off.
- ▼ Do not bend the material in multiple form, put one over another. **(Figures 2)**.
- ▼ Do not allow the machine to be operated with the retainer dismantled. **(Figures 3)**.

## 5. WARRANTY

The producer will only accept the warranty and responsibility subject to the following terms and conditions:

- ▼ Observe all protective precautions.
- ▼ Observe the warning signs.
- ▼ Do not operate the machine without grounded power.
- ▼ Do not replace failure parts and apparatus other than the genuine ones manufactured by **SIMA**.
- ▼ Observe the instructions specified in the safety guidelines.
- ▼ Observe the guidelines for safety, and efficient use.
- ▼ Observe the instructions for installation.
- ▼ Observe the conditions for loading, transportation, and unloading of the machine.
- ▼ Operate the machine by qualified operators.
- ▼ Observe the measurements, dimensions and the quality of material specified in the nameplate.
- ▼ Use always the machine in conformance with its production purposes.
- ▼ The power connection is to be made by a qualified electrician.
- ▼ Do not allow the machine to be operated when any of its part is disassembled.
- ▼ Do not change the motor.
- ▼ Observe the instructions for proper service and maintenance.
- ▼ Follow always the instructions for proper bending forms **(Figures 4, 5 and 6)**.

## 6. PROTECTIVE PRECAUTIONS

### 6.1 Protective Cloths

- Protective helmets
- Goggles
- Boots with steel heads.
- Gloves

Use the above protective material when you work on the machine. In case of not use these protective materials note that there is always a risk of injury such as hand-cut and/or hand-caught.

### 6.2. Working Garments

Note that the following are the things and garments **not convenient** to wear against the risk of injury and caught during working with the machine: long hairs, dresses with long arms, identity disks or jewellery, long working aprons etc.

## 7. TRANSPORTING

Utilize a forklift and/or a mobile, or a bridge-crane for transporting and lifting the machine. Use forklifts only when the machine is in a container. Put the machine in a container using wooden wedges under its wheels so as they do not touch on the bottom of a container, or locate it in a container with its wheels disassembled. Use steel ropes, chains and/or polyester tackle-block for lifting the machine. Use the lifting collets for crane hook to lift it without its container. Employ experienced or specialized people or subcontractors for lifting purposes.

### Warning!

Move the machine without causing any vibration. Do not transport it in wet conditions.

Please forward to the producer a report for the parts lost or damaged during transportation.

- Take maximum capacities of transportation and lifting machinery and equipment into your consideration.
- Take the centre of gravity of the machine into consideration during lifting it.

**Note:** Observe all instructions written on the warning labels

**FIGURE 14**

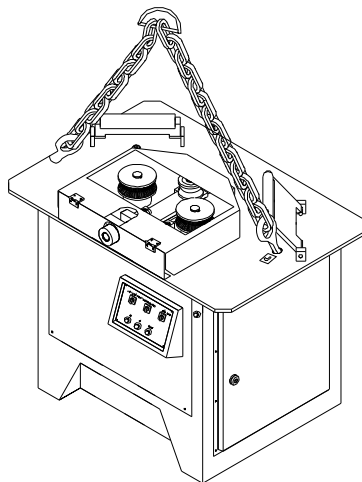



## 8. CHECKS AND ADJUSTMENTS

FIGURE 15

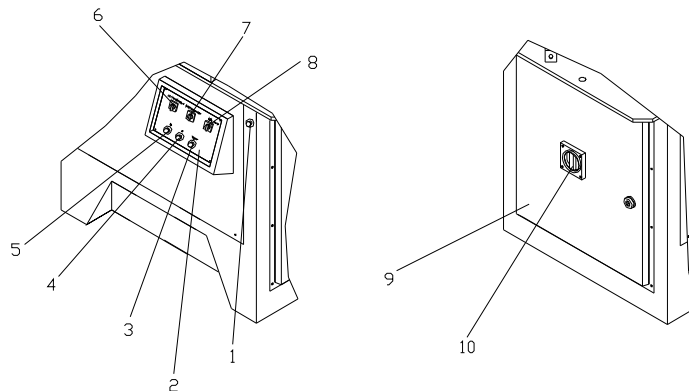

No	BUTTON	FUNCTION
1	LEFT/ STOP/ RIGHT	Ensures the machine to rotate to the right or left direction.
2	ON	Ensures the machine to be started.
3	MAN/ AUTO	Ensures the machine to be controlled automatically or manually.
4	OFF	Ensures the machine to be stopped.
5	POWER LED	Indicates the power in the system is on when the button (ON) is pressed on.
6	EMERGENCY STOP	Provides the machine to be stopped in emergency by disconnecting the power.
7	MAIN SWITCH	It is such a toggle switch ensuring the power input for the machine (0 means the machine is off, and 1 is on.)
8	POWER PANEL	It is such a component ensuring and controlling power to be supplied for the machine.

### 8.1 Adjustment of thermal current field, and motor circuit breaker

It is ex-works adjusted by its manufacturer as 8.6 A for 1.5 -2.5 kW motor with 750 -1.500 rpm. **(Figure 15)** Do not change this adjustment. The motor circuit breaker is installed onto the machine to de-energize the motor in order the machine not to be damaged when it takes excessive current. Turn the switch to the position (1) for re-starting the machine in case of circuit breaking. Under no circumstances the circuit breaker is dismantled.

**Note:** Should the machine be stopped by pressing the emergency stop knob turn the MAN/AUTO switch to the MAN position and the LEFT/STOP/RIGHT switch to the reverse of direction in that moment, and then to the direction of arrow the Emergency Stop, and press the foot pedal and pull the material compressed out of the machine.

## 8.2. Bending Adjustments

Turn the switch (MAN/AUTO) to the MAN position, close the shield and push the material to the direction of arrow by pressing the foot pedal down. Make adjustments both in diameter and in pitch by means of the adjustment bracket and the bending slope. Make the adjustment of diameter by means of turning the adjustment bolt and moving the adjustment roller forward and back (**Figure 4**) (Closer the adjustment roller to the fixed roller smaller the diameter (D) of the material is, and *vice versa*). To adjust the pitch (t) among the spiral circles lift the bending slope up and down by means of the bolt underneath (**Figure 4**). Lower the slope smaller the pitch is, and *vice versa*. Following the adjustments required shift the machine in AUTO position and start to make serial bending (**Figure 6**).

**Note:** The rollers of the machine continue to turn as long as the foot pedal is pressed down. The rotation of rollers stop if the foot pedal is stopped pressing. The rollers start to turn if the foot pedal is pressed one time whilst the machine is on AUTO position. Press one time again onto the foot pedal to stop it again.

FIGURE 4

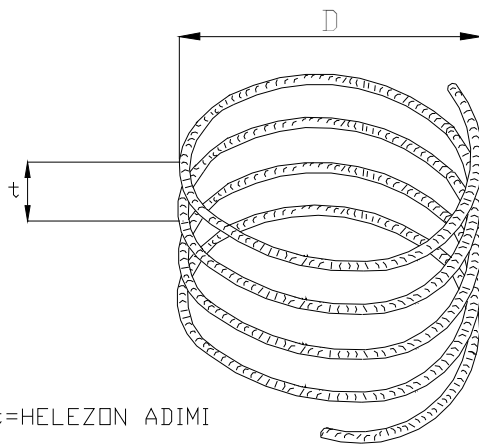

t=HELEZON ADIMI  
D=DEMIR DIS CAPI

FIGURE 5

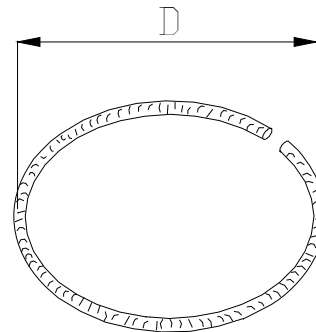

D=DEMIR DIS CAPI

**FIGURE 6**

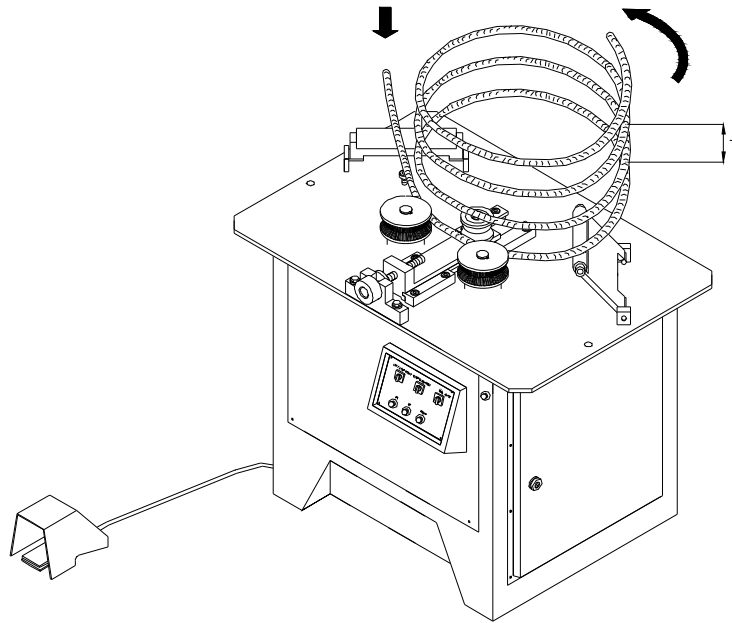

## **9. MAINTENANCE AND LUBRICATION**

Note that the proper maintenance is very important in order to prolong the service life of the machine, and to ensure the bending works in safety. We recommend the users are to establish a reliable system to control and maintain the machine. Please refer to the following instructions when you need. Use the lubrication oil no.140 for the gearbox of the machine.

**FIGURE 7**

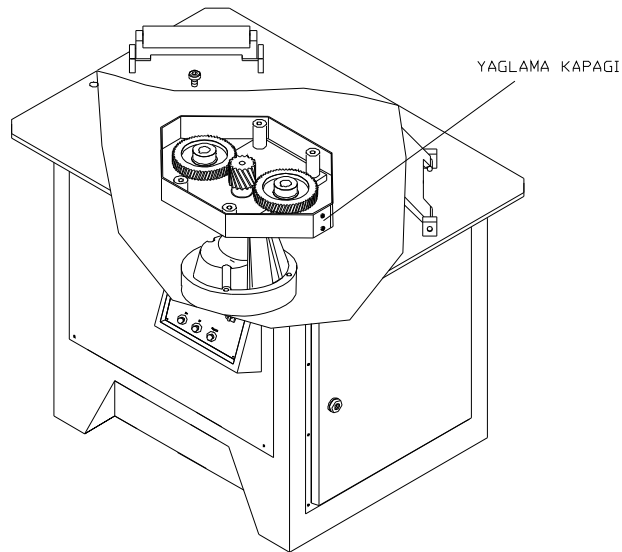

### **Daily Maintenance**

- Clean thoroughly dust and burrs on the machine by brush.
- Use brushes to clean the top of machine.
- Check if an abnormal sound from the machine.

### **Weekly Maintenance**

- Clean and grease the moving parts actuating the adjustment bracket.

### **Monthly Maintenance**

- Check the bending pins and brackets. Replace the bent and/or cracked parts.
- Check if any leakage from the gearbox.

### **Biannual Maintenance**

- Check and tighten all bolts and nuts of the machine.

### **Annual Maintenance**

- Change the gearbox lubrication oil.
- Check and replace if any damaged or failure parts.
- Check and replace if any damaged or failure seals and ball bearings.

## **10. TROUBLESHOOTING**

Refer to the Troubleshooting Chart below for the failures, errors and/or troubles, which may be take place during utilization of the machine.

**Warning! Disconnect first the power by turning the main switch to the (0) position in case of a need to open the lid of power panel for troubleshooting. Do not allow the people other than a qualified electrician to make a check and/or a repair in the power panel.**

NO	SYMPTOM	POSSIBLE CAUSE	SOLUTION
1.	Machinery fails to operate.	<ol style="list-style-type: none"> <li>1. Power supply is interrupted and/or one of the phases is short.</li> <li>2. Emergency stop knob is remained pressed.</li> <li>3. Protection switch is cut-out</li> <li>4. The Left/Stop/Right switch is closed.</li> <li>5. The lid of power panel is opened or is not closed properly.</li> <li>6. The STOP SLOW FAST switch is on the STOP position.</li> </ol>	<ol style="list-style-type: none"> <li>1. Check power supply and phases.</li> <li>2. Check the knob. To open turn it to the arrow direction on the knob if it is remained pressed.</li> <li>3. Check protection switch. Turn it to Position (1) if it is off.</li> <li>4. Check the switch. Turn it to right or left if it is on the stop position.</li> <li>5. Check the power panel lid.</li> <li>6. Check the switch. Turn it to the position required.</li> </ol>
2.	Protection switch cuts-out continuously.	<ol style="list-style-type: none"> <li>1. Diode is burned.</li> <li>2. Motor is burned.</li> <li>3. Machine bends material with larger diameter than its capacity.</li> <li>4. Short phase in power supply.</li> <li>5. Transformer is burned.</li> <li>6. Short circuit or damage in cables.</li> </ol>	<ol style="list-style-type: none"> <li>1. Check the diode.</li> <li>2. Check the motor.</li> <li>3. Check the material in accordance with the information about the kind of material and dimensions on the nameplate.</li> <li>4. Check the phase of power network.</li> <li>5. Check the transformer.</li> <li>6. Check the cable and connections</li> </ol>
3.	Machinery fails to operate despite the foot pedal is pressed.	<ol style="list-style-type: none"> <li>1. The plug is off.</li> <li>2. The pedal is defected.</li> <li>3. Contactors in electrical system are defected.</li> </ol>	<ol style="list-style-type: none"> <li>1. Check the plug.</li> <li>2. Check if the pedal is defected.</li> <li>3. Check the contactors in the electrical system.</li> </ol>
4.	Emergency stop does not operate.	<ol style="list-style-type: none"> <li>1. The emergency stop contactor is defected.</li> <li>2. Cable connections are off.</li> </ol>	<ol style="list-style-type: none"> <li>1. Replace the emergency stop.</li> <li>2. Check the cable connections</li> </ol>

5.	Abnormal sound comes out.	<ol style="list-style-type: none"> <li>1. Ball-bearings are worn out.</li> <li>2. Impeller touches with the bonnet.</li> <li>3. Gears are broken.</li> <li>4. No oil left in the gearbox.</li> <li>5. Short phase in power supply.</li> <li>6. Machine operates overcapacity.</li> <li>7. The brake in electro magnetic machines does not open or the broken lining of brake touches.</li> </ol>	<ol style="list-style-type: none"> <li>1. Check the ball-bearings</li> <li>2. Check the impeller bonnets.</li> <li>3. Check the gears</li> <li>4. Check the gearbox oil.</li> <li>5. Check the phases</li> <li>6. Check the material in accordance with the dimensions on the nameplate.</li> <li>7. Check the brake and linings if they operate properly.</li> </ol>
7.	Oil leakage from the machine	<ol style="list-style-type: none"> <li>1. The air ventilation plug of gearbox is not installed.</li> <li>2. The packing O-ring of motor leaks</li> <li>3. The fixing bolts of the gearbox are loose.</li> </ol>	<ol style="list-style-type: none"> <li>1. Check if the plug is screwed.</li> <li>2. Check the motor from the impeller side. Replace the packing O-ring if it leaks.</li> <li>3. Check and tighten all fixing bolts.</li> </ol>

## PARTS LIST

No	PART NUMBER	PART NAME	UNIT
1	01	HOUSING	1
2	02	TABLE PLATE	1
3	03	BEARING 6213 ZZ	4
4	04	AXLE	2
5	05	Ø 65 AXLE RING	2
6	06	Ø 120 HOLE RING	2
7	07	Ø WEDGE 12x8x45 DIN 6885	2
8	08	GEAR Z=63 Mn=3	2
9	09	Ø 40 AXLE RING	2
10	10	REDUCER CONNECTION FLANGE	1
11	11	BELOW PROTECTIVE PLATE	1
12	12	M16 SPRING WASHER DIN 1440	4
13	13	M16x40 BOLT 8,8 DIN 933	4
14	14	PINION GEAR Z=25 MN=3	1
15	15	GEARBOX	1
16	16	M10 SPRING WASHER DIN 1440	4
17	17	M10x30 BOLT 8,8 DIN 933	4
18	18	WEDGE 8x7x51DIN 6885	1
19	19	MOTOR	1
20	20	SPRING WASHER DIN 1440	4
21	21	BOLT	4
22	22	BELOW PROTECTIVE COVER	1
23	23	M10x15 BOLT 8,8	4
24	24	CONNECTION THRUST	4
25	25	M12x30 BOLT 8,8 DIN 912	8
26	26	ADJUSTMENT THRUST	1
27	27	AXLE	1
28	28	Ø 40 AXLE RING	1
29	29	BEARING 6210 ZZ	2
30	30	MOBILE ROLLER	1
31	31	Ø 50 AXLE RING	1
32	32	ADJUSTMENT SCREW	1
33	33	CHANNEL	1
34	34	M 16 SPRING WASHER DIN 1440	2
35	35	M16x50 BOLT 8,8 DIN 933	2
36	36	WEDGE 14x9x45 DIN 6885	2

PARTS LIST			
No	PART NUMBER	PART NAME	UNIT
37	37	STABLE ROLLER	2
38	38	Ø 50 AXLE RING	2
39	39	LAUNCHING PAD	2
40	40	STEEL ROLLER	2
41	41	BEARING 6003 ZZ	4
42	42	ROLLER AXLE	2
43	43	PROTECTIVE CONNECTION PLATE	1
44	44	M16x15 BOLT 8,8 DIN 7991	2
45	45	HINGE	2
46	46	PROTECTIVE COVER	4
47	47	M6x15 BOLT 8,8 DIN 7991	1
48	48	ELECTRIC PANEL	1
49	49	FOOT PEDAL	1
50	50	MAINTANANCE COVER	1
51	51	M6x30 BOLT 8,8 DIN 7991	4
52	52	HEAD PANEL COVER	1
53	53	CONTROL PANEL COVER	1
54	54	M6x15 BOLT 8,8 DIN 7991	4
55	55	M6x30 BOLT 8,8 DIN 7991	4
56	56	PANEL LOCK	2
57	57	KEY	1
58	58	PANEL COVER	2
59	59	M8x10 BOLT 8,8 DIN 417	1
60	60	M12x30 BOLT 8,8 DIN 933	2
61	61	M10 SPRING WASHER DIN 1440	4
62	62	M10x30 BOLT 8,8 DIN 933	4
63	63	EMERGENCY STOP	1
64	64	COVER	1
65	65	M6x10 BOLT 8,8 DIN 933	2



