



simasa

- ⓔS MANUAL DE INSTRUCCIONES ORIGINAL
- ⓖB ORIGINAL USER GUIDE
- ⓕR MANUEL ORIGINAL D'UTILISATION
- ⓖO MANUAL DE INSTRUÇÕES ORIGINAL
- ⓓE URSPRÜNGLICHES GEBRAUCHSANWEISUNG
- ⓖL ORYGINALNA INSTRUKCJA OBSŁUGI
- ⓔ دليل المستعمل الأصلي
- ⓔT MANUALE D'ISTRUZIONI ORIGINALI
- ⓓUS Инструкция по эксплуатации (завода изготовителя)

CX-16

CX-20

CX-25

C/ Albuñol, par.250
Pol. Ind. Juncaril,
18220 ALBOLOTE (Granada) ESPAÑA
Telf: (+34)958 490 410
Fax: (+34) 958 466 645
info@simasa.com
www.simasa.com

INDEX

INDEX	2
1. GENERAL INFORMATION	3
2. GENERAL DESCRIPTION	3
3. TRANSPORTATION	3
4. SUPPLY CONDITIONS	4
5. PICTOGRAMAS	4
6. ASSEMBLING INSTRUCCIONS	4
7. EXPLOXION VIEW OF THE MACHINE	4
8. SAFETY RECOMMENDATIONS	5
9. ELECTRICAL CONNECTION	5
10. STOPPER ADJUSTMENT	6
11. CHECKING THE MACHINE OUT BEFORE STARTING TO CUT	6
12. MAINTENANCE	6
12.1 OIL LEVEL CONTROL AND OIL CHANGE	7
12.2 CHANGE OF BLADES	7
12.3 CARBON BRUSHES	7
13. CUTTING PERFORMANCE	8
14. TECNICAL CHARACTERISTICS	8
14.1 CUTTING CAPACITY	8
15. WARRANTY	9
16. SPARE PARTS	9
17. ENVIRONMENT PROTECTION	9
18. DECLARATIONS ON NOISE	9
19. DECLARATIONS ON MECHANIAL VIBRATIONS	9

1. GENERAL INFORMATION

WARNING: Please read and understand perfectly the present instruction before using the machine.

SIMA S.A. thanks you for your trust in our products and for purchasing the PORTABLE HYDRAULIC SHEAR.

This manual provides you with the necessary instructions to start, use, maintain and in your case, repair of the present machine. All aspects as far as the safety and health of the users is concerned have been stated. Respecting all instructions and recommendations guarantees safety and low maintenance. As such, reading this manual carefully is compulsory for any person responsible for the use, maintenance or repair of this machine.

It is recommended to have always this manual in an easily accessible place where the machine is being used.

2. GENERAL DESCRIPTION

CX model portable hydraulic shears SIMA S.A., have been designed and manufactured to be used in work sites to cut steel reinforced and flat bars for construction, using interchangeable blades, mounted onto the cutting jaws.

Any other use of the machine is considered inadequate and can cause danger. Therefore, it is expressly prohibited.

- The manual shear model CEL has been designed and manufactured to cut flat and reinforced steel bars used for construction and passive steel armatures for structural concrete by means of two interchangeable blades mounted onto the cutting jaw.
- The cutting operation is done manually by pushing the bar on the roller, inserting the bar into the cutting throat between the two knives.
- It has a handle for easy transport or reorientation of the machine.
- The internal mechanical components that are subject to wearing have been treated thermally to guaranty their long durability and high performance.
- The main body of the machine is a mono-block made of cast iron.
- Cutting is performed by means a switch.
- The blades are rectangular with four cutting faces.
- Internal mechanisms are bathed in oil.
- The electrical equipment of the machine complies with the EC safety norms.

3. TRANSPORTATION

Transportation of the portable hydraulic shearing machines CX models for their versatility and low weight need not be transported by lifts, therefore carrying the machines short distances are easily done by one person.

4. SUPPLY CONDITIONS.

Portable hydraulics shearing machines CX models are supplied in sealed and strengthened packaging.

The machines are introduced on the packaging which in turn serves as a carrying case so they can withstand storage at various heights if necessary.

Along with the machine you will find:

- An instruction manual.
- An Allen wrench.
- A flat wrench.

5. PICTOGRAMAS.

Pictograms included in the machine entail the following:



**READ INSTRUCTIONS
MANUAL**



**USE HELMET AND EYE AND EAR
DEFENDERS**



USE SAFETY GLOVES



USE SAFETY FOOTWEAR

6. ASSEMBLING INSTRUCCIONS

The machine is delivered mounted and prepared to operation.

7. EXPLOXION VIEW OF THE MACHINE

1. Housing
2. Knives
3. Adjustable cap
4. Removable side handle
5. Cylinder
6. Trigger
7. Oil plug
8. Engine
9. Switch
10. Carbon brush cap

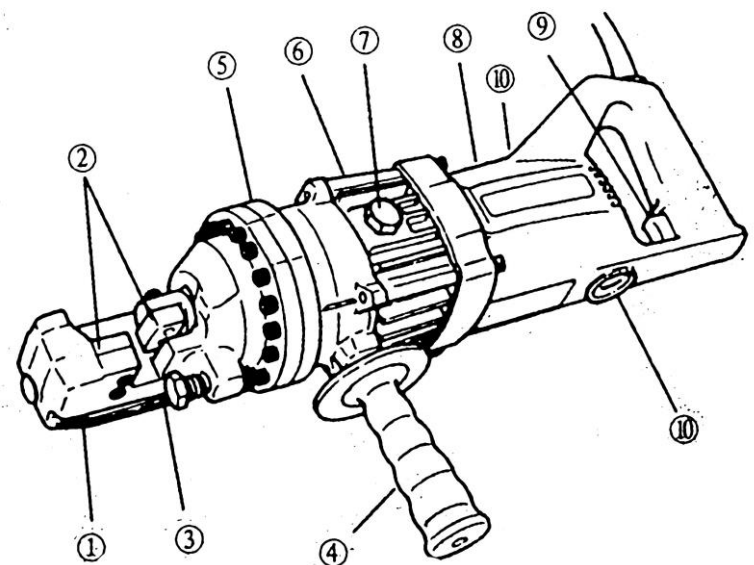

8. SAFETY RECOMMENDATIONS

This chapter covers basic safety rules for using the machine. By working with the machine you must comply with the following instructions:

- Before starting up the machine please read the instructions and make sure safety norms are respected. Learn how to stop the machine in a fast and safe way.
- It is recommended to use safety glasses, safety boots, gloves etc. Please always use approved materials.
- Always use Individual Protection Equipment (IPE) in accordance with the type of work you are effectuating.
- Prohibit strangers to access the place of work of the machine.
- Work clothes are not supposed to have loose articles that can cling into movable parts of the machine.
- The damaged electrical cables should be urgently replaced.
- Unplug the machine from the electricity and never manipulate nor operate on the mechanical nor electrical elements of the machine while the engine is on.
- Never use the machine for purposes other than those it has been designed for.
- Secure the machine with a safety rope when working at high levels as scaffolds.
- Install safety barriers to collect the excess material when working in high places.
- Do not use the machine in the presence of gases, fumes, liquids or flammable products.
- Do not use the machine with wet hands, rain or in wet environments.
- Keep work area tidy up.
- Work with the machine in well illuminated.
- **VERY IMPORTANT:** The electrical ground should always be connected before start the machine.
- Use normalized extension cords
- Make sure the mains voltage supply which will be attached the machine coincides with the voltage indicated on the characteristics plate of the machine.
- Make sure the extension cord to power the machine is not in contact points of high temperature, oil, water, sharp edges, avoid being trampled or crushed by passing vehicles and placing things on it.
- Do not use pressurized water to clean circuits and electrical components.

ATTENTION: You are to follow all safety recommendations mentioned in the present user manual and comply with all labour risks prevention norms in every location..

SIMA SA is not responsible for any consequences that may result in inappropriate use of the machines above

9. ELECTRICAL CONNECTION

Machines with electrical motor should always be connected to a normalised switchboard that disposes of a magneto-thermal switch and a differential in accordance with the characteristics of the motor:

WARNING: Do not plug the machine to the electricity if you are not sure of the available electrical tension. If the tension is not correct, the engine will undergo irreparable harm or out of service.

WARNING: Never manipulate the power cables or any electrical equipment of the machine, if you have not totally unplugged the machine from the electricity.

If you use extension cords to power the machine, make sure they have a minimum cross-section as indicated by the table below.

WIRE LENGTH	110/115v	230v
	Wire size /AWG)	Ø Nominal
> (10 feet) o (3 metres)	16	1,0 mm ²
> (15 feet) o (5 metres)	14	1,25 mm ²
> (30 feet) o (9 metres)	10	1,5 mm ²

10. STOPPER ADJUSTMENT

Main stopper function is to keep the steel bar in the correct position as the bar diameter to be cut. The optimal brew bar is an angle of 90 ° to the cutting blades.

CAUTION: If stopper is not set correctly, it could result in excessive wear of the cutting blades, also because spare material could shoot off with strength and also damage to the cutting unit.

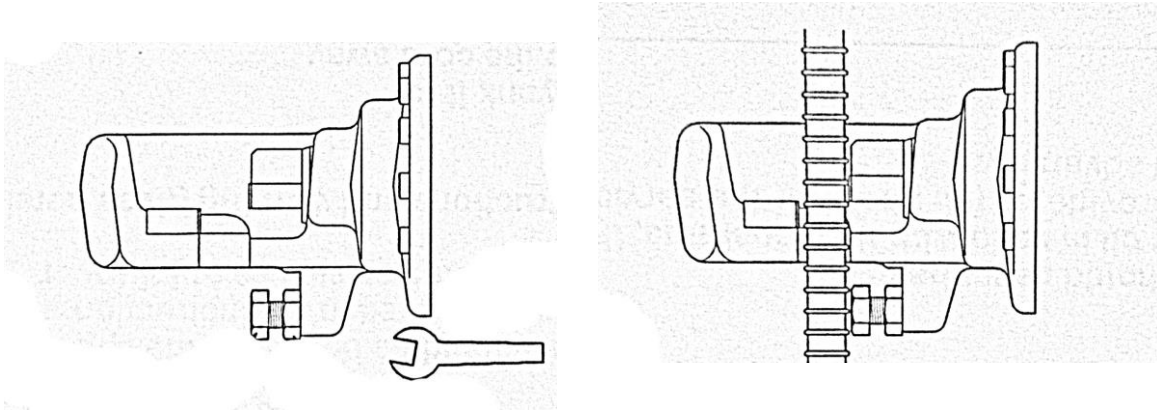

11. CHECKING THE MACHINE OUT BEFORE STARTING TO CUT

Before working with the machine you should check the following points.

1. Check looseness of the all elements of the machine.
2. Check the oil level.
3. Check the status of the stopper bar.
4. Verify power source is appropriate to the cutter

CAUTION: If the voltage is too high, the motor will burn out. If the voltage is too low, you will not have enough energy to cut. Never use direct current.

5. Verify that the installation has electric ground.
6. Verify that the cable is not damaged and that the plug connection is not deteriorated.

CAUTION: If using extension cords, check that section of the wires is adequate.

7. Before connecting the machine, make sure the switch is not blocked in running position.
8. Keep the handle clean and free of grease or dirt

HEATING

In cold weather, before starting work with the cutting unit, you have to warm up for proper operation. Without putting a bar between the knives, press the trigger between 30 and 60 seconds for the hydraulic oil reaches optimum viscosity. Make the piston out and 15 to 20 times.

12. MAINTENANCE

In order to keep your machine in perfect condition we should regularly monitor the following points:

- Keep clean the piston housing free of dirt and iron filings. Clean before and after use the machine with a brush, never use air or water pressure.
- Make sure all screws or bolts are not loose or missing
- After 500 cuts, check the knives screws looseness.
- Check every 500 cuts the cylinder screws are not loose, so it would mean loss of power
- Check the cutting edges of knives, remember that each blade has four cutting edges
- Check oil level daily.

12.1 OIL LEVEL CONTROL AND OIL CHANGE

Failure to maintain proper oil level will cause a drop in hydraulic pressure and loss of power cut.

We recommend changing the hydraulic oil at least once a year or immediately in the event that shows traces of oil contamination. The recommended hydraulic oil and abrasion should be antifoaming and abrasion resistant, viscosity grade VG46, SHELL TELLUS OIL 46, MOBIL DTE-25 or ESSO UNI POWER SQ-46.

Steps to follow:

1. Make sure the machine is unplugged from the power supply
2. Unscrew the oil plug and put the mouth under shear so that the oil falls by gravity. This has prepared a container for collecting the oil
3. Once the oil stop falling out, tilt the machine back so that the remaining oil in the piston can get out too.
4. Now tilt the machine forward so that the oil containing the bomb can be released
5. Once the machine is empty completely, slowly fill in with new oil shear from the top hole filling which it was created for this purpose
6. Put the cap slightly clenched.
7. Connect the hydraulic portable shear to the power supply to operate the machine so the piston makes its way about three times
8. Disconnect the shearing machine and empty the oil following the steps 2 to 8.
9. Refill with new oil shear and put the oil plug again back.

Note: Dispose of hydraulic oil according to local regulations in your area. Never place in the sea, river, lakes and sewage systems.

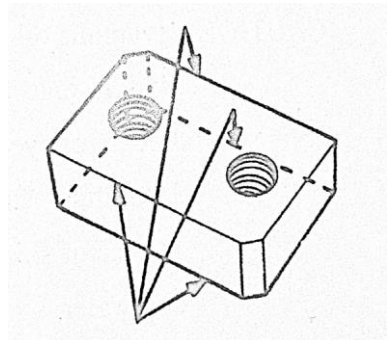

12.2 CHANGE OF BLADES

If any of the blades of the machine is damaged through use, you must change the cutting edge. To change the cutting edge will have to loosen the screws that secure the blade with the supplied allen wrench, change the cutting edge and re-tighten. (Remember that the blades have four cutting edges)

12.3 CARBON BRUSHES

Inspect carbon brushes once a month. The normal life of carbon brushes is 200 hours. Proceed to replace if the length is less than 6mm

ATTENTION: The worn brushes will result in the loss of power, the engine overheat and damage the armour will be irreparable

To change carbon brushes proceed as follows:

1. Unplug the unit from the mains supply.

2. Unscrew both ends of carbon brushes.
3. Replace the brushes.
4. Re-threading the tops of the brushes

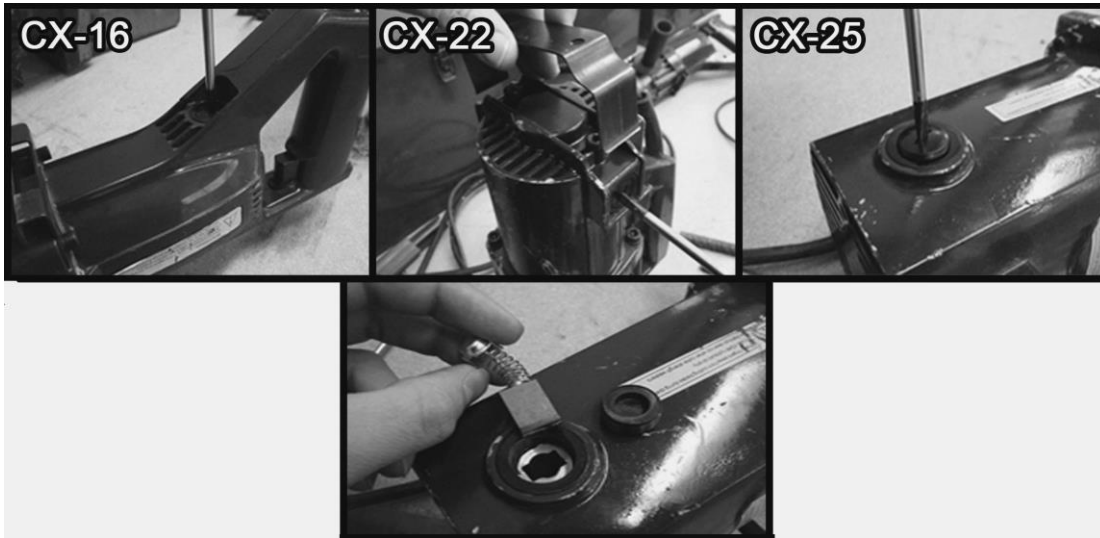

13. CUTTING PERFORMANCE

To performance an adequate cut, we will proceed as follows:

1. Place the iron bar between the knives.
2. Adjust the stop bar.
3. Connect the machine.
4. Press the trigger until cut the rod and the piston completely back to stay in place.

CAUTION: There is always a possibility that the cut end can be ejected powerfully, especially if the piece has less than 30cm in length.

14. TECNICAL CHARACTERISTICS

MODEL	CX-16		CX-20		CX-25	
MOTOR TENSION	220/230V	110V	220/230V	110V	220/230V	110V
	50/60Hz	60Hz	50/60Hz	60Hz	50/60Hz	60Hz
MOTOR POWER	850W	900W	950W	1250W	1600W	1700W
DIMENSIONS	465x230x155		405x120x220		485x150x260	
WEIGHT	8Kg		13Kg		24,5Kg	
CUTTING SPEED	2,5-3"		3-3,5"		5-5,5"	

14.1 CUTTING CAPACITY

Elastic limit R=N/mm ² 650			
Tensile strength R=N/mm ² 850			
	CX-16	CX-20	CX-25
Ø MIN. CUTTING CAPACITY	Ø4	Ø4	Ø4
Ø MAX CUTTING CAPACITY	Ø16	Ø20	Ø25

15. WARRANTY

SIMA, S.A. the manufacturer of light machinery for construction possesses a net of technical services "SERVI-SIMA".

Repairs under warranty made by SERVI-SIMA are subject to some strict condition to guaranty a high quality and service.

SIMA S. A. guarantees all its products against any manufacturing defect; to take into account the conditions stated in the attached document "WARRANTY CONDITIONS". The latter would cease in case of failure to comply with the established payment terms. SIMA S.A. reserves its right to bring modifications and changes to its products without prior notice.

16. SPARE PARTS

The spare parts for the bending and combined machines, manufactured by SIMA, S.A. are to be found in the spare parts plan, attached to this manual.

To order any spare part, please contact our alter-sales service clearly indicating the serial number of the machine, model, manufacturing number and year of manufacturing that show on the characteristics plate.

17. ENVIRONMENT PROTECTION



Raw materials have to be collected instead of throwing away residuals. Instruments, accessories, fluids and packages have to be sent into specific places for ecological reutilisation. Plastic components are marked for selective recycling.



R.A.E.E. Residuals arising of electrical and electronic instruments have to be stored into specific places for selective collection.

18. DECALARATIONS ON NOISE

The acoustic levels emitted by the MACHINE are inferior to 70 dB (A)

19. DECLARATIONS ON MECHANIAL VIBRATIONS

The machine does not present any source of mechanical vibrations that cause risks to the health or safety of the operator.



SOCIEDAD INDUSTRIAL DE MAQUINARIA ANDALUZA, S.A.

POL. IND. JUNCARIL, C/ALBUÑOL, PARC. 250

18220 ALBOLOTE (GRANADA)

TEL.: 34 - 958-49 04 10 - Fax: 34 - 958-46 66 45

MANUFACTURER OF LIGHT MACHINERY FOR CONSTRUCTION

SPAIN